

(No Model.)

F. MALLET-GUY.

MACHINE FOR THE MANUFACTURE OF WIRE SPIRALS.

No. 372,423.

Patented Nov. 1, 1887.

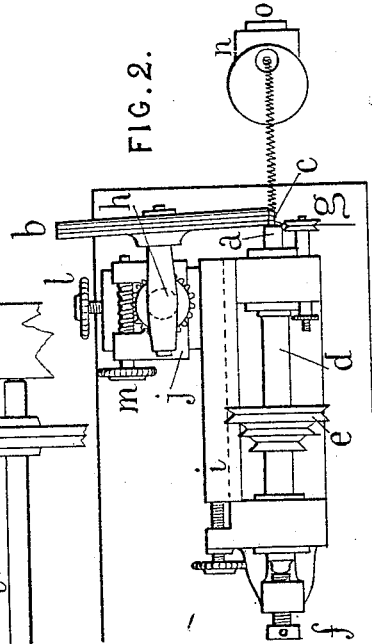
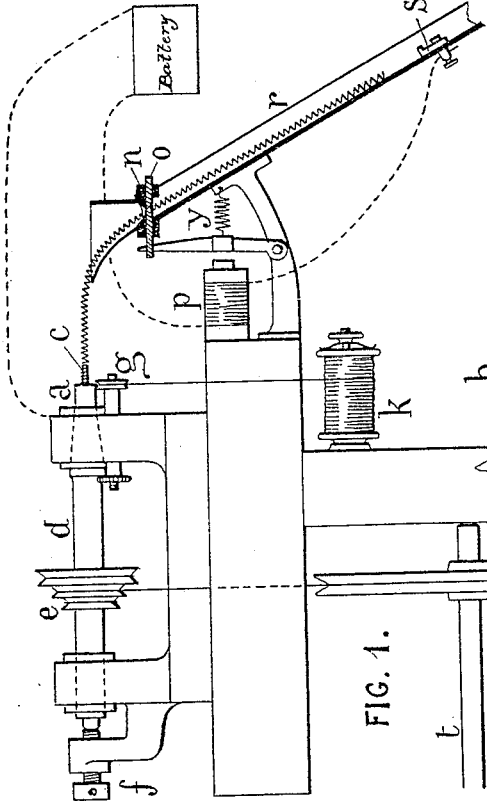
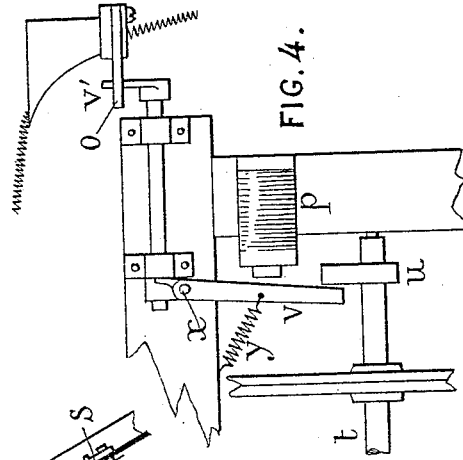
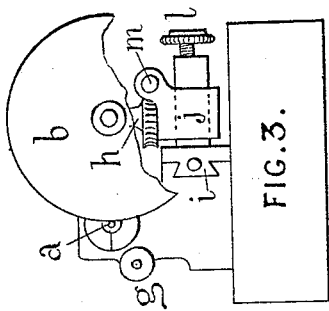

Witnesses

Chas. H. Smith
Geo. T. Pinkney

Inventor

Francis Mallet-Guy.
for *Lemuel W. Ferrell* atty

10
64

~~231~~
90
~~194~~

5110
x 5270
x 5270

UNITED STATES PATENT OFFICE.

FRANCIS MALLET-GUY, OF PARIS, FRANCE.

MACHINE FOR THE MANUFACTURE OF WIRE SPIRALS.

SPECIFICATION forming part of Letters Patent No. 372,423, dated November 1, 1887.

Application filed June 13, 1887. Serial No. 241,132. (No model.) Patented in France November 18, 1885, No. 170,550.

To all whom it may concern:

Be it known that I, FRANCIS MALLET-GUY, a citizen of the Republic of France, residing at Paris, France, have invented a new and useful Improvement in Machines for the Manufacture of Fine-Wire Helices, of which the following is a specification.

It is well known that helices of very fine wire, sometimes called "bullion," are used in making fringe and in ornamental drapery, &c. It is manufactured by hand, and attempts to make it by machinery have been unsatisfactory; on account of the difficulty of pushing the helix uniformly forward as the winding progresses.

The present machine accomplishes the winding of this bullion with accuracy and rapidity.

In the accompanying drawings, Figure 1 is an elevation, Fig. 2 a plan view, and Fig. 3 an end view, of the mechanism made use of by me.

I make use of a mandrel, *a*, at the end of a small shaft supported in a lathe-stock, and this mandrel is revolved and the wire used for making the ribbon is wound upon the mandrel. A delivery-disk, *b*, of wood or other compressible material is used for the purpose of moving the helix of wire uniformly and delivering it off the end of the mandrel or needle, and at the same time the helical wire is rendered firm.

Shears actuated by electricity are used to cut the helix into regular lengths as the manufacture goes on.

The mandrel *a* is part of or inserted into the shaft *d* of the lathe and receives its movement from a belt passing in one of the grooves of the cone *e*. This shaft turns at one end in a conical bearing that is held by a screw, so that the mandrel is properly supported against any end play or looseness. The mandrel *a* ends in a cylindrical or slightly-conical needle, *c*, which at its base has the diameter necessary for the wire helix. The wire is supplied from a bobbin, *k*, under the proper tension, and passes over a grooved pulley, *g*, which guides it directly to the base of the needle, around which it is wound by the rotation of the lathe.

The delivery-disk *b* is of wood or other compressible material, and its edge is pressed against the needle *c* with sufficient force to cause the convolutions of the wire to bury

themselves slightly in it. The disk receives a rotary movement from the revolving helix as it is wound, and its circumference receives impressions from the wire itself in the shape of small parallel grooves, in which pass successive convolutions, traveling like a screw as the wire helix revolves.

The bullion is carried along uniformly by its own rotation, the convolutions screwing themselves into the grooves of the disk as they are wound.

The disk *b* is supported by carriages, one of which, *i*, moves parallel to the shaft of the lathe, and the other, *j*, at right angles to it. It is supported by a small stock, *h*, which can be revolved around a vertical axis on the carriage *j* by means of a worm-pinion, *m*. This arrangement allows the disk to be placed at an inclination which causes the whole width of its edge to act on the helix or only to bear near one edge. It can also be moved parallel to the shaft, to be placed at the desired part of the needle *c*, or at right angles to the shaft, to regulate the pressure against the convolutions. This pressure is regulated according to the degree of hardness of the wire in the helix. The screw *l* acts on the carriage *j* to regulate this pressure.

The same object may be obtained by means of a fixed disk, piece of wood, or similar material, against which the spindle rubs as it is rotated with and upon the needle, and impress thereon a portion of a female screw, which causes the helix to be delivered off the needle by the helix acting as a screw and moving itself along as it is wound. This method can be used when the wire is sufficiently strong and stiff to prevent the friction from detaining it. In this case a simple piece of wood fastened on the carriages might take the place of the disk. The uniform forward movement given by this disk allows the helix to be wound more or less open. All that is necessary is to impress the grooves on the disk by a portion of the ribbon that has the desired distance between the convolutions.

Ribbons or bullion can be made composed of several wires wound side by side, and by varying the colors new effects can be obtained which are very difficult to obtain by the present way of manufacturing.

The ribbon can be made in any desired

lengths, which could afterward be cut according to the uses it is put to; but as this article is generally put on the market in regular lengths, the machine performs also the cutting operation by means of the very simple apparatus that I am about to describe. On leaving the mandrel or needle the ribbon or helix falls in a funnel, the bottom of which is formed by a steel plate, *n*, in which is a circular opening with a cutting-edge. Under this plate works a cutter, *o*, actuated by an electro-magnet, *p*. After passing the shears formed by the plate *n* and cutter *o*, the ribbon slides along an incline, *r*, along which contact-plate *s* can be moved and held by a clamping-screw. This plate closes the circuit of the electro-magnet as soon as it comes in contact with the ribbon or bullion, and the helix or ribbon is then cut by the action of the electro-magnet on the devices, and thereby the circuit is broken, the shears open by means of the spring *y*, and the ribbon keeps on descending till a new contact is established with the plate *s*.

The electric current employed in cutting the ribbon can pass directly through the helix or ribbon, as illustrated in the drawings. In this case the current starts from the battery and passes through the electro-magnet and contact-plate *s*, and then through the ribbon to the lathe-stock and battery. With this arrangement the ribbon may offer too much resistance to the passage of the current, and to avoid this the ribbon or helix may act on a very light lever to move the same and close the circuit through a conductor of greater cross-section.

Instead of having the electro-magnet *p* to act directly on the shears, such shears may be actuated from the machine, and the electro magnet will only cause this movement to take place at the right time, as shown in Fig. 4.

On the shaft *t* a cam, *v*, is keyed, which acts by means of the levers *v v'* on the shears *o*. The lever *v* is pivoted at *x*, to allow it to be moved out of the way of the cam by a spring, *y*, and the tension of this spring is overcome by the electro-magnet at the time of contact. At this moment the lever *v* is attracted and acted upon by the cam. This causes the other lever to act on the shears to cut the ribbon. The current is thereby broken, and the spring *y* brings the lever *v* back out of the way of the cam.

I am aware that previous to my invention a friction disk has been used in wire coiling machines to keep the wire close to the mandrel as the wire is wound spirally upon said mandrel; and I am also aware that a metal disk having a peripheral groove has been used to give the pitch to the helix of wire and to determine the diameter of the helix; but I am not aware of any instance in which a disk or

block of wood or other soft material having grooves therein corresponding to the pitch of the spiral has been used to act as a female screw to the helix upon the mandrel and thereby cause said helix to pass freely off the mandrel. The wire employed in the manufacture of bullion is very fine, and it is sometimes flattened to form a ribbon. Said ribbon has little or no elasticity; hence a friction-roller is not necessary to keep it to the mandrel, for the great difficulty in the manufacture of bullion is the tendency of the flattened wire to cling to the mandrel and for one coil to pass upon its neighbor. By the use of a disk or block of wood or other soft material, having grooves therein corresponding to the pitch of the helix, said block or disk acts as a female screw or nut upon the helix on the mandrel and causes, said helix to screw itself along upon the mandrel without it being possible for one spiral to pass upon another.

I claim as my invention—

1. The combination, with the revolving mandrel or needle, around which the helix of fine wire is wound, of a disk or block of wood or other soft material, having grooves therein corresponding to the pitch of the spirals of the helix wound upon said mandrel, and into which grooves the convolutions of the wire are sufficiently embedded to cause the delivery of the helix from the mandrel or needle by the revolution of the screw-shaped helix, substantially as specified.

2. The combination, with a revolving mandrel or needle, upon which the fine wire is wound, of a disk or block of wood or other soft material, having grooves therein corresponding to the pitch of the spirals of the helix wound upon said mandrel, the carriages *i* and *j* at right angles to each other for supporting the disk or block, and means for adjusting said carriages, substantially as and for the purposes specified.

3. The combination, with the revolving mandrel or needle, upon which the helix is wound, and means for delivering the helix from said mandrel, of a guide-trough for said helix, a cutter for cutting up the helix into lengths, an electro-magnet whose armature is connected to the cutter, a stop in the guide-trough for determining the length of the helix, and circuit-connections, substantially as specified, whereby the circuit is closed to said electro-magnet when the end of the helix comes in contact with said stop, as set forth.

The foregoing specification of my improvements in the manufacture of wire spirals signed by me this 14th day of May, A. D. 1887.

FRANCIS MALLET-GUY.

Witnesses:

ROBT. M. HOOER,

JOS. B. BOURNE.